



DOCK BUMPER APPLICATION GUIDE

IronGuard Safety Products
www.ironguardsafety.com

Toll Free Phone: 1.866.828.6737

Toll Free Fax: 1.844.899.0088

CONTENTS

Step #1	Determine Industry Type	3
Step #2	Determine Dock Usage and Conditions	3
Step #3	Determine if extra bumper projection is required.....	4
Step #4	Determine Height of Impact Range	5
Step #5	Determine if “Above Dock” protection is required.....	5
Step #6	Applying Above Dock Riser Brackets (if required).....	6

STEP #1 DETERMINE INDUSTRY TYPE

Refer to the guideline chart below for minimum bumper protection required based on the type of industry where the bumpers will be used.

Industry Type	Load Weight	Frequency (trailers per day)	Minimum Protection Required
Commercial	Light	1-2	Molded Bumpers
		3+	Laminated Bumpers
	Medium – Heavy	3+	Nytrex™ or Steel-Faced Bumpers
Distribution & Warehousing	Light – Medium	1-2	Laminated Bumpers
	Medium – Heavy	3+	Nytrex™ or Steel-Faced Bumpers
Manufacturing & Automotive	Light - Medium	All	Nytrex™ or Steel-Faced Bumpers
	Medium – Heavy	All	Nytrex™ Bumpers
Beverage, Paper & Packaging	Heavy	All	Nytrex™ Bumpers

STEP #2 DETERMINE DOCK USAGE AND CONDITIONS

Refer to this chart to understand the minimum bumper protection required for different types of traffic and loading conditions.

Dock Usage & Conditions	Load Weight	Frequency (trailers per day)	Minimum Protection Required
City Delivery & Cube Vans	Light	All	Molded Bumpers (rec. Laminated Bumpers)
Forklift Loading	All	All	Laminated Bumpers (rec. Steel-Faced Bumpers)
Yard Jockey / Shunt Trucks	All	All	Steel-Faced Bumpers (rec. Nytrex™ Bumpers)
B-Trains (double impact)	All	All	Nytrex™ Bumpers
Air-Ride Trailers	All	All	Nytrex™ Bumpers
Declined Approach	Light	All	Steel-Faced Bumpers
	Medium - Heavy	All	Nytrex™ Bumpers

STEP #3 DETERMINE IF EXTRA BUMPER PROJECTION IS REQUIRED.

Always use dock bumpers to keep truck a minimum of 4" away from any surface or equipment that could be damaged. Use this chart for information on specific conditions.

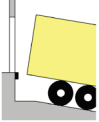
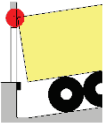
Condition	Extra Bumper Protection Required?	Notes																																							
Other dock equipment installed	ANALYSIS REQUIRED	Always consult OEM specifications of other loading dock equipment installed at dock position (dock levelers, truck restraints, dock shelters, etc.) for specific dock bumper protection requirements.																																							
Inclined Approach 	NO	In cases when a trailer is docked uphill into the building, standard 4" projection bumpers, if properly selected and installed, will offer adequate protection. <i>(Unless other dock equipment requirements or special conditions exist.)</i>																																							
Declined Approach 	YES	In cases when a trailer is docked downhill into the building, in most cases bumper protection must be extended to suit. The general rule is to add a minimum of 1" of bumper protection (beyond standard 4" or 6") for every 1% of decline. Eg. 3% decline = 4" bumper + 3" additional = 7" min. bumper protection. This chart keeps it simple: <table border="1" style="margin: 10px auto; border-collapse: collapse; text-align: center;"> <thead> <tr style="background-color: yellow;"> <th style="width: 30%;">Percent of Grade</th> <th style="width: 30%;">Optimum Bumper Projection</th> <th style="width: 30%;">Minimum Bumper Projection</th> </tr> </thead> <tbody> <tr><td>1%</td><td>7"</td><td>5"</td></tr> <tr><td>2%</td><td>8"</td><td>6"</td></tr> <tr><td>3%</td><td>9"</td><td>7"</td></tr> <tr><td>4%</td><td>10"</td><td>8"</td></tr> <tr><td>5%</td><td>11"</td><td>9"</td></tr> <tr><td>6%</td><td>12"</td><td>10"</td></tr> <tr><td>7%</td><td>13"</td><td>11"</td></tr> <tr><td>8%</td><td>14"</td><td>12"</td></tr> <tr><td>9%</td><td>15"</td><td>13"</td></tr> <tr><td>10%</td><td>16"</td><td>14"</td></tr> <tr><td>11%</td><td>17"</td><td>15"</td></tr> <tr><td>12%</td><td>18"</td><td>16"</td></tr> </tbody> </table> <p>Note: Declined approaches result in heavier trailer impact and heavier duty bumpers should be considered.</p>	Percent of Grade	Optimum Bumper Projection	Minimum Bumper Projection	1%	7"	5"	2%	8"	6"	3%	9"	7"	4%	10"	8"	5%	11"	9"	6%	12"	10"	7%	13"	11"	8%	14"	12"	9%	15"	13"	10%	16"	14"	11%	17"	15"	12%	18"	16"
Percent of Grade	Optimum Bumper Projection	Minimum Bumper Projection																																							
1%	7"	5"																																							
2%	8"	6"																																							
3%	9"	7"																																							
4%	10"	8"																																							
5%	11"	9"																																							
6%	12"	10"																																							
7%	13"	11"																																							
8%	14"	12"																																							
9%	15"	13"																																							
10%	16"	14"																																							
11%	17"	15"																																							
12%	18"	16"																																							
Yard Jockeys or Shunt Trucks	YES	The yard jockey raises the nose of the trailer, thereby tilting the top-backside in towards the building. Add an extra 4" of protection to the bumpers to keep the trailer at a safe distance. Notes: <ol style="list-style-type: none"> 1. Yard jockey use causes more face damage to bumpers and heavier duty bumpers should be considered. 2. Extending bumper projection may negatively affect lip purchase of existing dockleveler and dock seal/shelter. Be careful! 																																							

Increasing bumper projection can be accomplished in several ways:

1. Creating a cantilever dock by adding concrete to the face of the dock.
2. Removing existing dock bumpers and installing an **Extension Bracket** to extend bumper.
3. Installing an Extra Projection Bumper of the appropriate projection.

STEP #4 DETERMINE HEIGHT OF IMPACT RANGE

Ensuring adequate protection here will limit the potential damaging effects of truck over/under-ride. Once you know the lowest and highest impact points (off grade) of trailers, refer to this chart to understand the minimum bumper protection height required.

Height of Impact Range	Bumper Height	Bumper Style
Up to 8"	12"	Horizontal
8" to 16"	20"	Vertical
16" to 20"	24"	Vertical
20" to 30"	36"	Vertical
30" or higher	<i>Contact Customer Support</i>	

Notes:

1. 20" to 24" high vertical bumpers as minimum protection are always recommended.
2. For extra width requirements – consider extra width laminated bumpers (stacked for extra height protection) or side by side installation of vertical bumpers.

STEP #5 DETERMINE IF "ABOVE DOCK" PROTECTION IS REQUIRED

If the impact location of trailers is above dock level, Above Dock Riser Brackets will be required. Use the following chart as a basic guideline if trailer impact ranges are unknown.

Dock Height (off grade)	Riser Bracket Required?	Notes
46" or lower	YES	Most traffic can over-ride bumpers mounted lower than 46".
46" to 52"	ANALYSIS REQUIRED	Bumpers mounted at dock level generally offer adequate protection, but if high-bedded trailers (e.g. refrigerated trailers) or other conditions exist which may raise the trailer above this height (e.g. packed snow/ice), use Above Dock Riser Brackets.
52" or higher	NO	Bumpers mounted at dock level generally offer adequate protection.

Note: Trade-off may be necessary when considering Above Dock Riser Brackets as they may cause intrusion into the door opening.

STEP #6 APPLYING ABOVE DOCK RISER BRACKETS (IF REQUIRED)

Step 6a. Choose the desired RISE (A) based on the coverage needed. See Figure 1.

Step 6b. Ensure there is adequate installation space for the TOP PLATE (D) as it must be a minimum of 2" longer than the RISE (A) to offer maximum top impact protection. See Figure 2.

Step 6c. Choose the appropriate size dock bumper so that at least 60% of the entire height is "below dock". See figure 3.

Step 6d. Ensure the front plate of the bumper is a minimum of 2" longer than the bumper height. See figure 2 & 3.

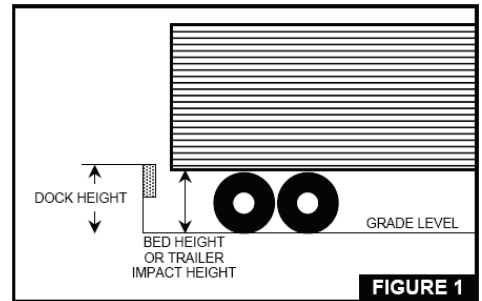

FIGURE 1

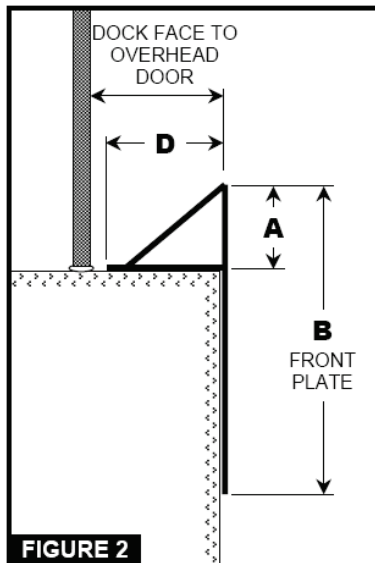

FIGURE 2

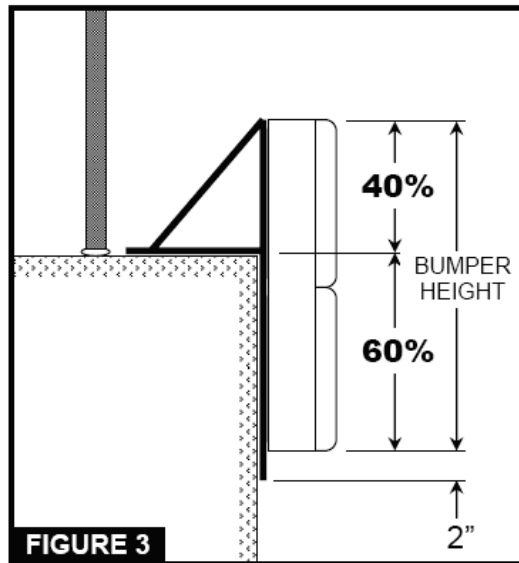

FIGURE 3

Step 6e. Use this convenient chart to help you determine the correct sizes and bracket type:

A Desired Rise	D Minimum Top Plate	B Minimum Front Plate	Minimum Bumper Height	Bracket Type
6" or less	8"	22" (20" w/extra-proj brkt)	20"	Standard
7"	9"	22" (20" w/extra-proj brkt)	20"	High Rise
8"	10"	22" (20" w/extra-proj brkt)	20"	High Rise
9"	11"	26" (24" w/extra-proj brkt)	24"	High Rise
10"	12"	26" (24" w/extra-proj brkt)	24"	High Rise
11"	13"	32" (30" w/extra-proj brkt)	30"	High Rise
12"	14"	32" (30" w/extra-proj brkt)	30"	High Rise
13" or higher		<i>Consult Applications</i>		
VHL or Drive-Thru Applications		Use VHL Riser Bracket		

Then choose one of the following designs and supply dimensions for all the letters.

Standard Dimensions:

- C = 10"
- G = 10"

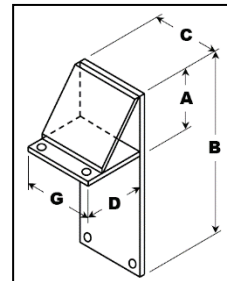

STANDARD RISER

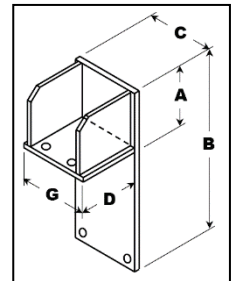

HIGH RISE

Step 6f. Certain situations may require combining riser bracketing and extra bumper projection to achieve adequate bumper protection. In these cases, select one of the extra-projection risers or select extra-projection dock bumpers (and have them welded to riser brackets).

Standard Dimensions:

- C = 10"
- G = 10"

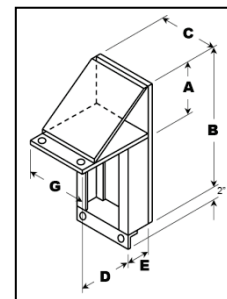

STANDARD RISER WITH EXTENSION

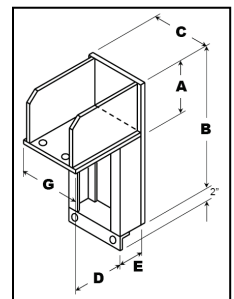

HIGH RISE WITH EXTENSION

Step 6g. In dock applications where the door opening width is small and there is not enough space between the dock leveler and the wall for a standard width riser bracket, a riser with a cut-out can be manufactured. Select one of the following:

Standard Dimensions:

- C = 10"
- G = 5"

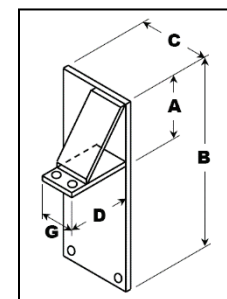

STANDARD RISER WITH CUTOUT

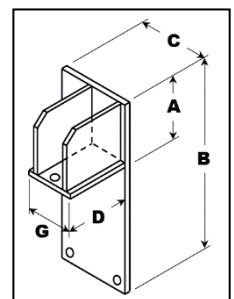

HIGH RISE WITH CUTOUT